

CG137-08 Gas Engine

298 bkW (400 bhp) @ 1800 rpm

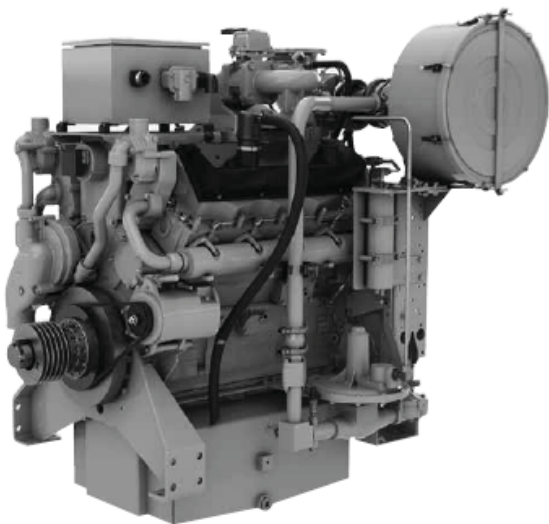

Image shown may not reflect actual engine configuration

Cat® Engine Specifications

V-8, 4-Stroke-Cycle

Emissions

NSPS Site Compliant Capable

Bore

137 mm (5.4 in)

Stroke

152 mm (6 in)

Displacement

18 L (1099 cu. in)

Compression Ratio

8.3:1

Aspiration

Turbocharged-Aftercooled

Rotation (from flywheel end)

Counterclockwise

Flywheel

SAE No 14 or 18

Flywheel Housing

SAE No. 0

Flywheel Teeth

136

Power per Displacement

22.2 bhp/L

Capacity for Liquids

Cooling System 55 L (14.5 Gal)

Lube Oil System (refill)....148 L (39 Gal)

Oil Change Interval

750 hours

Governor

Electronic ADEM™ A4

Ignition, Protection

Electronic ADEM A4

FEATURES AND BENEFITS

Engine Design

- Tough and durable, with field-proven head design
- When configured with customer-supplied air fuel ratio control and three-way catalyst, the engine is capable of meeting NSPS and non-attainment area emissions levels.
- Operator interface panel allows setup and servicing without a laptop
- Delivers full speed turndown over a wide range of site conditions and fuels, even at the catalyst emissions setting
- Factory-installed components with single connection point eases packaging

Advanced Digital Engine Management

The ADEM A4 system represents the next generation of engine management systems while reducing the number of mechanical components and easing troubleshooting. Features include:

- Electronic ignition
- Electronic governing/speed control
- Start/stop logic
- Engine protection and monitoring

Full Range of Attachments

A wide variety of factory-installed attachments are available to simplify packaging, saving time and effort.

Gas Engine Rating Pro (GERP)

GERP is a PC-based program designed to provide site performance capabilities for Cat natural gas engines for the gas compression industry. GERP provides engine data for your site's altitude, ambient temperature, fuel, engine coolant heat rejection, performance data, installation drawings, spec sheets, and pump curves.

Product Support Offered Through Global Cat Dealer Network

- More than 2,200 dealer outlets
- Cat factory-trained dealer technicians service every aspect of your Oil & Gas Engine
- Caterpillar parts and labor warranty
- Preventive maintenance agreements available for repair-before-failure options
- S•O•S program matches your oil and coolant samples against Caterpillar set standards to determine:
 - Internal engine component condition
 - Presence of unwanted fluids
 - Presence of combustion by-products
 - Site-specific oil change interval

Over 80 Years of Engine Manufacturing Experience

Over 60 years of natural gas engine production. Ownership of these manufacturing processes enables Caterpillar to produce high quality, dependable products.

- Cast engine blocks, heads, cylinder liners, and flywheel housings
- Machine critical components
- Assemble complete engine

Web Site

For all your Oil & Gas power requirements, visit www.cat.com

BUILT FOR IT.™



Air Inlet System

- Air cleaner — single element with service indicator
- Optional air inlet adapter and rain cap — recommended for weather protection

Control System

- ADEM A4
- Class 1, Division 2, Group C & D

Cooling System

- Jacket water thermostats and housing -- full open temperature 98 °C (208 °F)
- Jacket water pump — gear driven, centrifugal, non-self-priming
- Aftercooler water pump — gear driven, centrifugal, non-self-priming
- Aftercooler core— for treated water and sea air atmosphere

Exhaust System

- Exhaust manifolds — watercooled
- Exhaust elbows —dry 203 mm (8 in)

Flywheels & Flywheel Housings

- Flywheel, SAE No. 14 or 18
- Flywheel housing, SAE No. 0
- SAE standard rotation

OPTIONAL EQUIPMENT

Charging Alternator

- 24V, 60A CSA alternator

Exhaust System

- Exhaust flex fitting
- Exhaust elbow
- Exhaust flange — ANSI

Instrumentation

- Operator interface panel
- Operator interface panel enclosure
- 15', 25', 50' interconnect harness

Fuel System

- Gas pressure regulator
- Natural gas carburetor

Lube System

- Crankcase breather —top mounted
- Oil cooler
- Oil filter —RH
- Oil filler in valve cover, dipstick — RH

Protection System

ADEM A4 protection. The following include alarm and shutdown:

- Inlet manifold air temperature
- Inlet manifold air pressure
- Oil pressure
- Coolant temperature
- Engine speed (overspeed)
- Battery voltage

The following is display only:

- Service hours

General

- Paint, Caterpillar yellow
- Crankshaft vibration damper and drive pulleys
- Lifting eyes
- Cylinder block inspection covers

Starting System

- Air pressure regulator
- Air start silencer
- Vane starter
- Electric starter
- Turbine starter

Fuel System

- Fuel filter

Air Inlet System

- Precleaner
- Rain cap

		DM9293-00
Engine Power @ 100% Load	bkW (bhp)	298 (400)
Engine Speed	rpm	1800
Max altitude @ Rated Torque and 38°C (100°F)	m (ft)	1524 (5000)
Speed Turndown @ Max Altitude, Rated Torque, and 38°C (100°F)	%	18
Aftercooler Temperature		
JW Temperature	°C (°F)	99 (210)
SCAC Temperature	°C (°F)	54 (130)
Compression Ratio		8.3:1
Emissions (NTE)*		
NOx	g/bkW-hr (g/bhp-hr)	4893 (11.78)
CO	g/bkW-hr (g/bhp-hr)	4893 (11.78)
VOC**	g/bkW-hr (g/bhp-hr)	101 (0.22)
Heat Rejection		
Heat Rejection to Jacket Water JW & OC	bkW (Btu/min)	295 (19,070)
Heat Rejection to Aftercooler @ 100% Load	bkW (Btu/min)	17 (1005)
Heat Rejection to Exhaust @ 100% Load	bkW (Btu/min)	185 (10,492)
Heat Rejection to Atmosphere @ 100% Load	bkW (Btu/min)	35 (1980)
Intake System		
Air Inlet Flow Rate @ 100% Load	N•m3/min (scfm)	2.77 (531)
Gas Pressure	kPag (psig)	10-34 (1.5-5.0)

* at 100% load and speed, listed as not to exceed

** Volatile organic compounds as defined in U.S. EPA 40 CFR 60, subpart JJJJ

*** ISO 3046/1

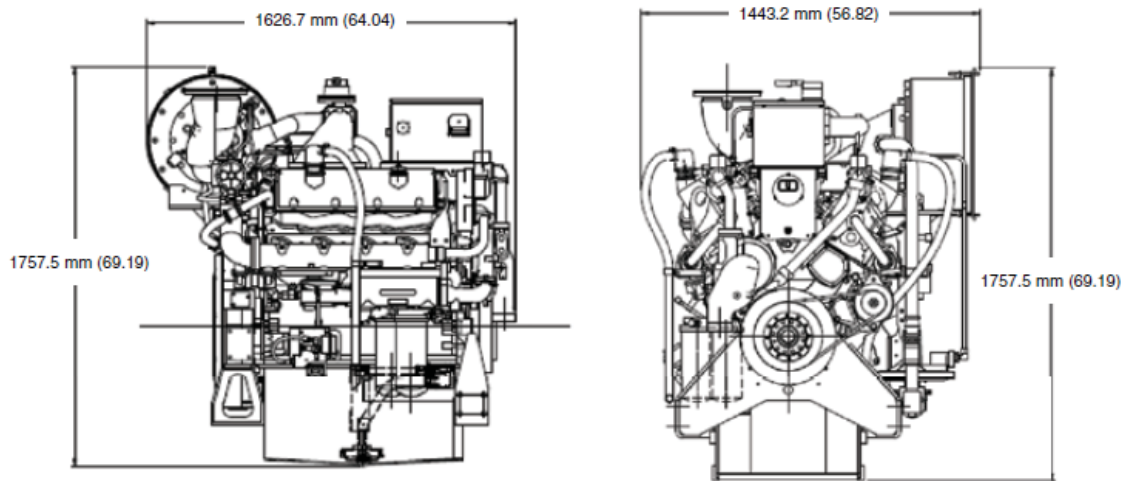

Note: Dimensions are in mm (inches).

Dimensions		
Length	1626.7 mm	64.04 in
Width	1443.2 mm	56.82 in
Height	1757.5 mm	69.19 in
Weight	2835 kg	6250 lb

Rating Definitions and Conditions

Engine performance is obtained in accordance with SAE J1995, ISO3046/1, BS5514/1, and DIN6271/1 standards.

Transient response data is acquired from an engine/generator combination at normal operating temperature and in accordance with ISO3046/1 standard ambient conditions. Also in accordance with SAE J1995, BS5514/1, and DIN6271/1 standard reference conditions.

Conditions: Power for gas engines is based on fuel having an LHV of 33.74 kJ/L (905 Btu/cu ft) at 101 kPa (29.91 in Hg) and 15°C (59°F). Fuel rate is based on a cubic meter at 100 kPa (29.61 in Hg) and 15.6°C (60.1°F). Air flow is based on a cubic foot at 100 kPa (29.61 in Hg) and 25°C (77°F). Exhaust flow is based on a cubic foot at 100 kPa (29.61 in Hg) and stack temperature.

To find your nearest dealer, please visit:
www.cat.com

Subject to change without notice.
LEHW0153-04

© 2015 Caterpillar All Rights Reserved. Printed in Germany.
CAT, CATERPILLAR, their respective logos, MaK, "Caterpillar Yellow" and the POWER EDGE trade dress, as well as corporate and product identity used herein, are trademarks of Caterpillar and may not be used without permission.