



Locomotive Engine **C27 ACERT™**

**708 bkW/950 bhp
@1800 rpm**

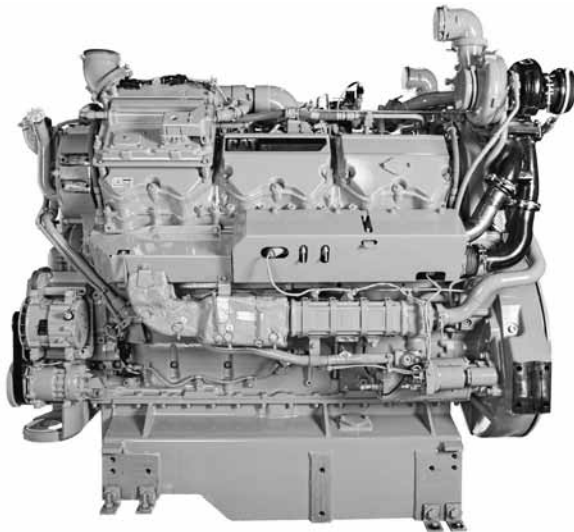

Image shown may not reflect actual engine configuration

EU Stage IIIB

CAT® ENGINE SPECIFICATIONS

V-12, 4-Stroke-Cycle Diesel

Emissions.....	EU Stage IIIB
Peak Torque at Speed.....	4166 N•m (3072 lb-ft) @ 1350 rpm
Bore.....	137.7 mm (5.4 in)
Stroke.....	152.4 mm (6 in)
Displacement.....	27 L (1648 in ³)
Aspiration.....	Turbocharged Governor and Protection .. Electronic ADEM™ A4
Engine Weight, Net Dry (approximate).....	2790 kg (6151 lbs)
Capacity for Liquids	
Lube System (refill).....	137 L (145 U.S. qts)
Cooling System.....	60 L (63 U.S. qts)
Oil Change Interval.....	250/500 hours
Rotation (from flywheel end)...	Counterclockwise
Flywheel and Flywheel Housing.....	SAE No. 1 (standard), SAE No. 0 (optional)
Flywheel Teeth.....	136

FEATURES

Emissions

- Designed to meet EU Stage IIIB emissions standards.
- On-engine NOx reduction system with optimized piston, ring, liner, and fuel system configuration to reduce NOx while minimizing in-cylinder sooting
- Aftertreatment features diesel oxidation catalyst

Engine Design

- Proven reliability and durability of engine and aftertreatment
- Broad operating speed range
- High power density
- PTO drive options provide flexible access to auxiliary power for pumps and other needs

Low Total Cost of Ownership

- Optimized fuel consumption
- Maintenance-free aftertreatment

Advanced Digital Engine Management

ADEM A4 control system providing integrated ignition, speed governing, protection, and controls, including detonation-sensitive variable ignition timing. ADEM A4 has improved: user interface, display system, shutdown controls, and system diagnostics.

Testing

Every engine is full-load tested to ensure proper engine performance.

Product Support Offered Through Global Cat Dealer Network

- More than 2,200 dealer outlets
 - Caterpillar factory-trained dealer technicians service every aspect of your locomotive engine
 - Caterpillar parts and labor warranty
- Preventive maintenance agreements available for repair-before-failure options

S•O•SSM program matches your oil and coolant samples against Caterpillar set standards to determine:

- Internal engine component condition
- Presence of unwanted fluids
- Presence of combustion by-products
- Site-specific oil change interval

Over 80 Years of Engine Manufacturing Experience

Ownership of these manufacturing processes enables Caterpillar to produce high quality, dependable products.

- Cast engine blocks, heads, cylinder liners, and flywheel housings
- Machine critical components
- Assemble complete engine

Web Site

For all your locomotive power requirements, visit www.cat-RailPower.com



Locomotive Engine

C27 ACERT™

**708 bkW
950 bhp**

STANDARD ENGINE EQUIPMENT

Air Inlet System

Twin rear-mounted turbochargers, ATAAC

Control System

Automatic altitude compensation; power compensation for fuel temperature; electronic diagnostics and fault logging; engine monitoring and protection system (speeds, temperature, pressure); J1939 Broadcast (diagnostic, engine status and control); ADEM A4 electronic control

Cooling System

Thermostats and housing; jacket water pump, gear-driven, centrifugal, RH

Exhaust System

Exhaust dry manifold, 127 mm (5 in) slip fit connection, diesel oxidation catalyst

Fuel System

Mechanical Electronic Unit Injection (MEUI) system; primary, secondary, and tertiary fuel filter; electronic fuel priming pump-integrated with primary fuel filter base; fuel transfer pump

Lube System

Oil cooler — RH; oil filler — RH; oil level gauge — RH; shallow rear sump oil pan — 250-hour; optional deep sump oil pan — 500-hour

DIMENSIONS (deep sump shown)

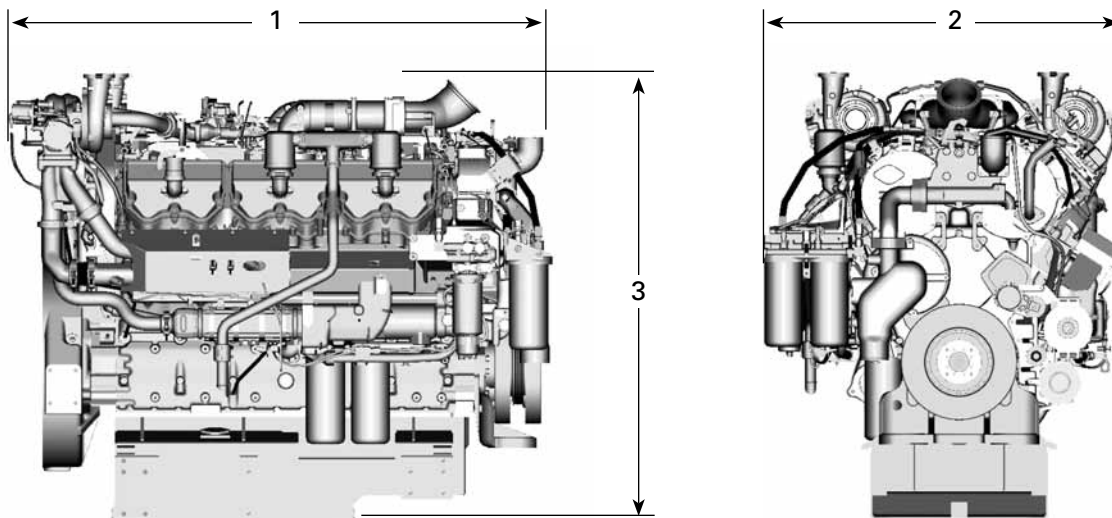

(1) Length — 1896 mm (75 in)

(2) Width — 1264 mm (50 in)

(3) Height — 1557 mm (61 in) deep sump
— 1298 mm (51 in) shallow sump

Note: Final dimensions and weight dependent on selected options



Locomotive Engine

C27 ACERT™

708 bkW
950 bhp

PERFORMANCE DATA — PRELIMINARY

Turbocharged — 1800 rpm

C Rating (DM9743-00)

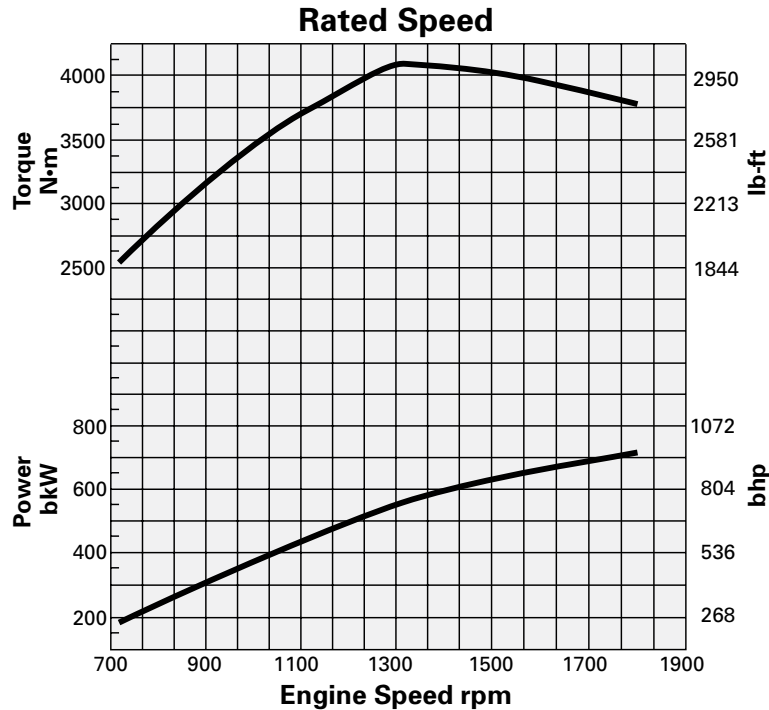

Peak Power

Peak Torque

Rating	Speed rpm	Peak Power bkW	Peak Power bhp	Speed rpm	Peak Torque N·m	Peak Torque lb-ft
C	1800	708	950	1350	4166	3072

RATING DEFINITIONS AND CONDITIONS

C Rating (Intermittent) service where maximum power and/or speed are cyclic (time at full load not to exceed 50%).

Engine Performance Diesel Engines — 7 liter and higher are based on SAE J1995, inlet air standard conditions of 99 kPa (29.31 in Hg) dry barometer and 25°C (77°F) temperature. Performance measured using a standard fuel with fuel gravity of 35° API having a lower heating value of 42 780 kJ/kg (18,390 btu/lb) when used at 29°C (84.2°F) with a density of 838.9 g/L.



Locomotive Engine

C27 ACERT™

708 bkW
950 bhp

CLEAN EMISSIONS MODULE AFTERTREATMENT CONFIGURATION

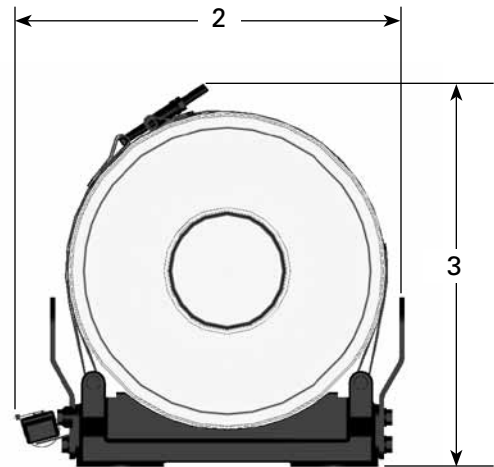
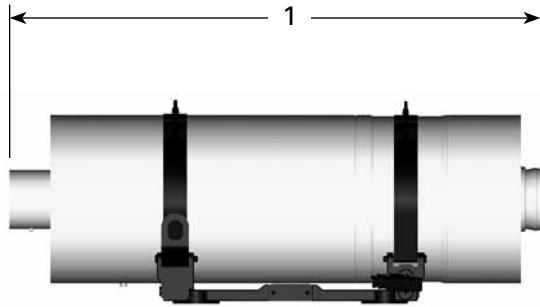

Images shown may not reflect actual aftertreatment.

AFTERTREATMENT DIMENSIONS*

Approximate Size and Weight

(1) Length — 1120 mm (44 in)

(2) Width — 400 mm (15.7 in)

(3) Height — 440 mm (17.3 in)

Weight — 66 kg (145 lbs)

*Dimensions and image are for individual canister. Two canisters are required. They can be shipped loose for customizable mounting options.

AFTERTREATMENT FEATURES

Mounting: Remote installation options provide OEM flexibility for many applications

Each canister features a single diesel oxidation catalyst. Two canisters required for compliance.

STANDARD EMISSIONS CONTROL EQUIPMENT

DOC: Diesel Oxidation Catalyst

NRS: NOx Reduction System

Materials and specifications are subject to change without notice. The International System of Units (SI) is used in this publication. CAT, CATERPILLAR, their respective logos, ACERT, ADEM, S•O•S, "Caterpillar Yellow" and the "Power Edge" trade dress, as well as corporate and product identity used herein, are trademarks of Caterpillar and may not be used without permission.